



Cell Culture Simplified



HAMILTON
THE MEASURE OF EXCELLENCE™

Cell culture. *Simplified.*

A Vision for Cell Culture

How can these elements be unified to remove the art?

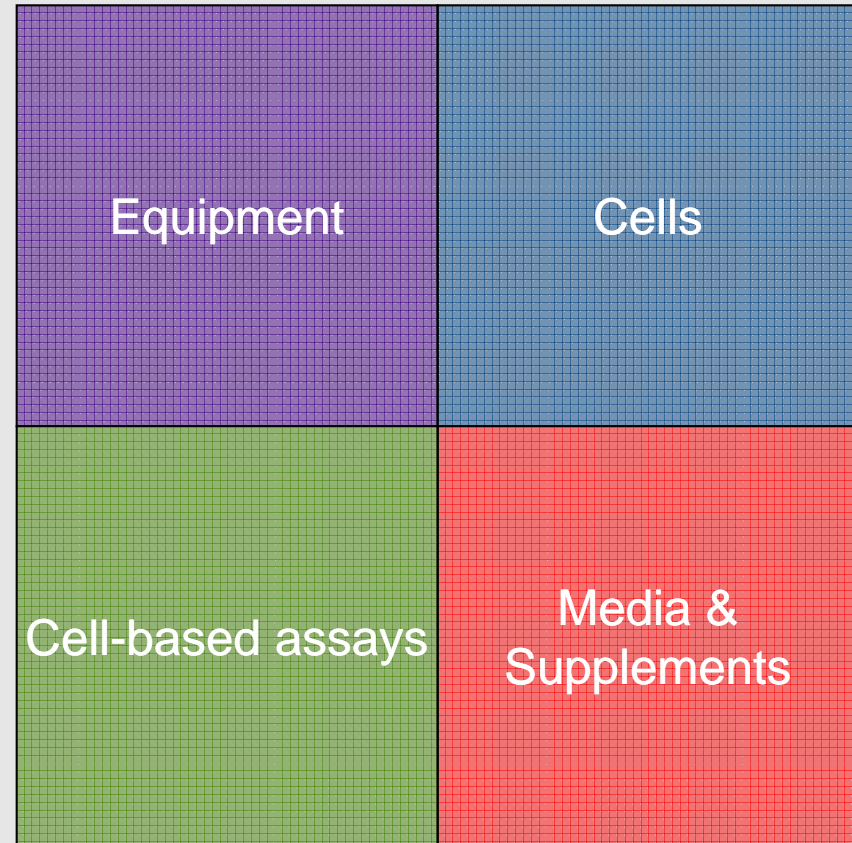

Cell culture. *Simplified.*

The BioLevigator



TheScientist 2009

TOP 10
INNOVATIONS

- Four independent positions
- CO₂ and temperature regulation
- Touchscreen interface
- Small bench-top footprint
- USB input/output
- Real time monitoring

Cell culture. *Simplified.*

The GEM and GEM+

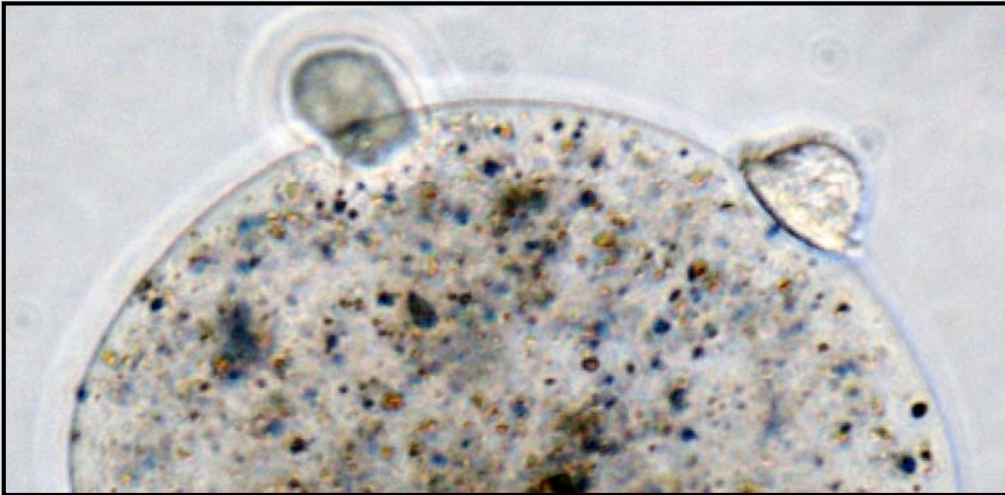

- Magnetic alginate microcarrier
- 75 um diameter
- Covalently bound protein coat supports multiple cell types
- Optically clear, non-autofluorescent
- Dissolvable

Cell culture. *Simplified.*

New Products

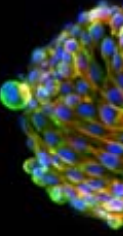
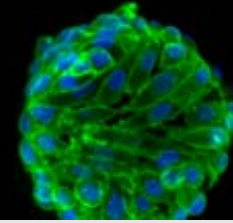
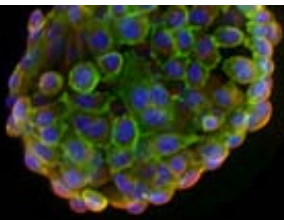

pH Monitoring

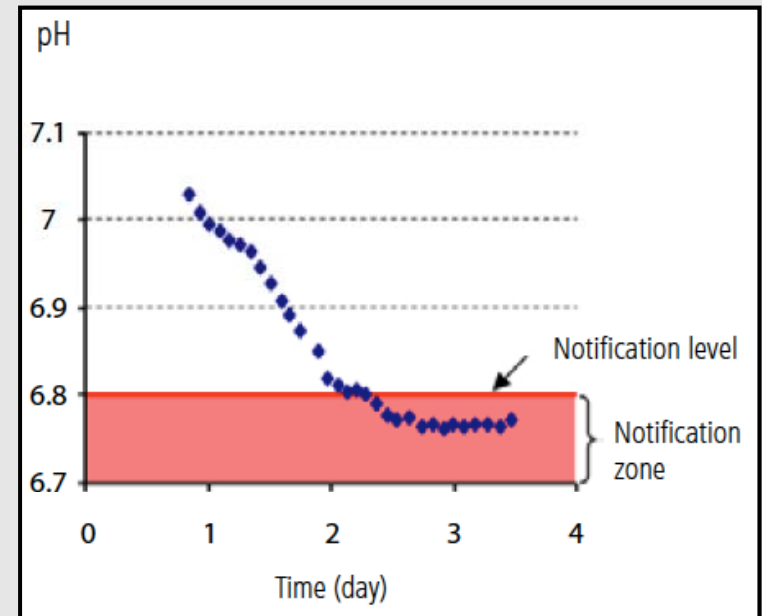
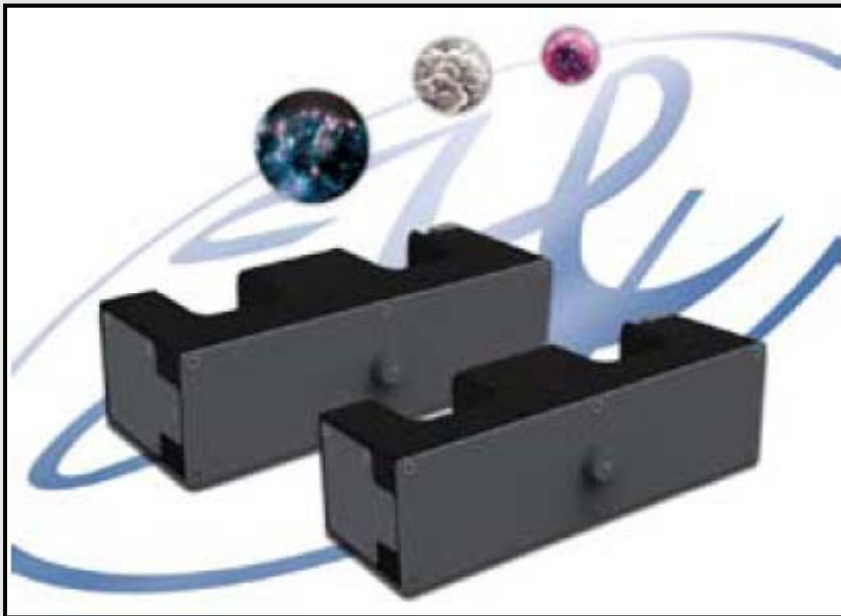

Cell culture. *Simplified.*

New Products

LeviTube

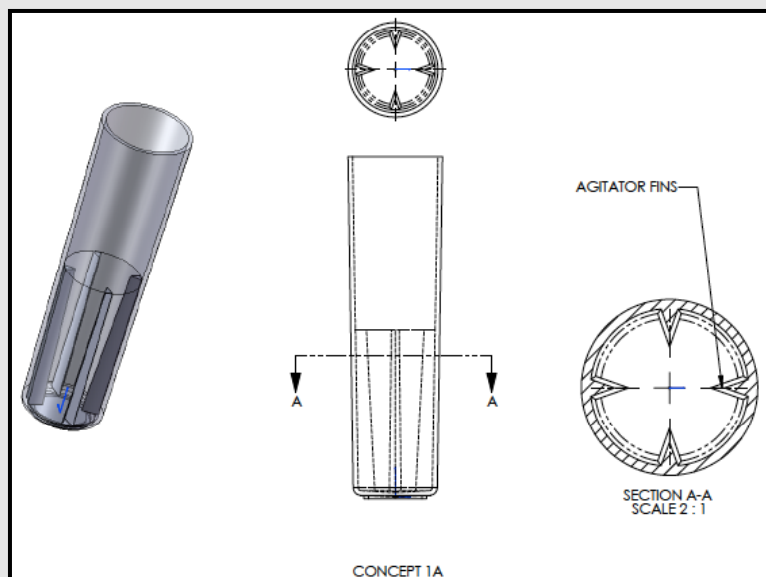

LeviTube v TPP Tube

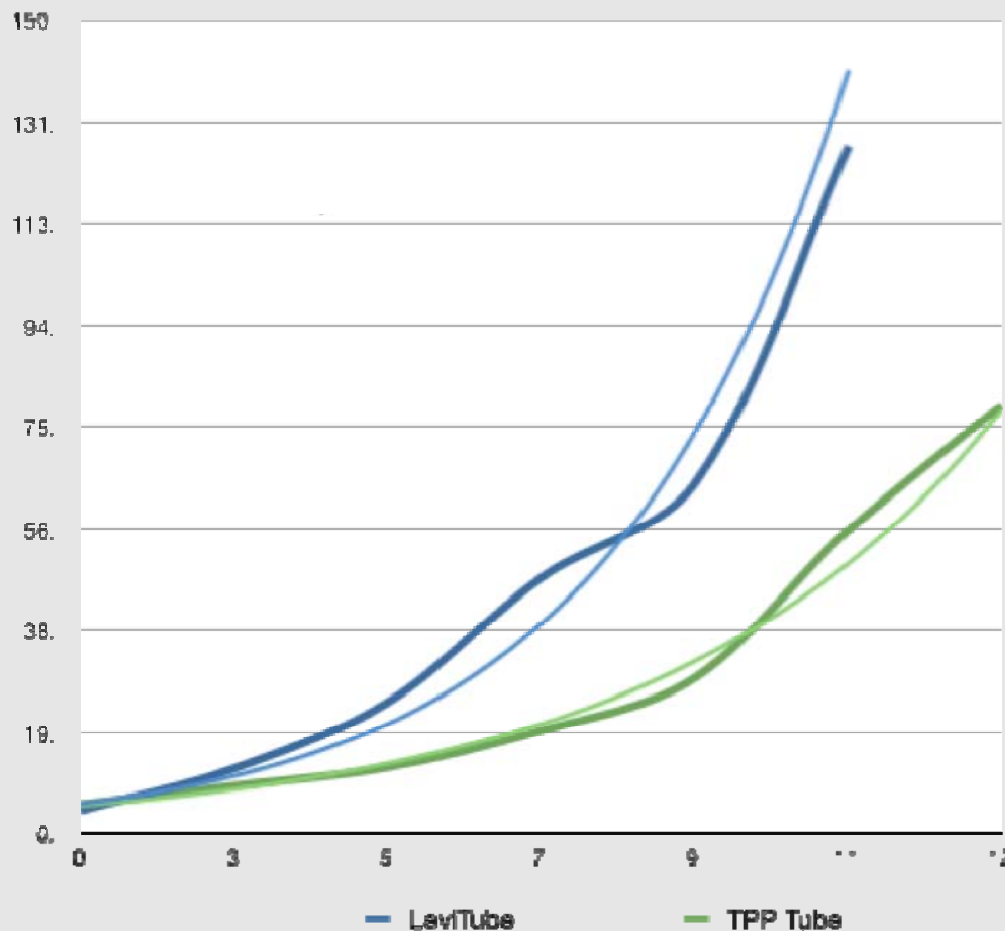

Cell culture. *Simplified.*

New Products

Cell Culture Services

- Identify substrate
- Optimize BioLevigator Settings
- Generate growth curves
- Cryopreservation studies
- Cell production for assay testing

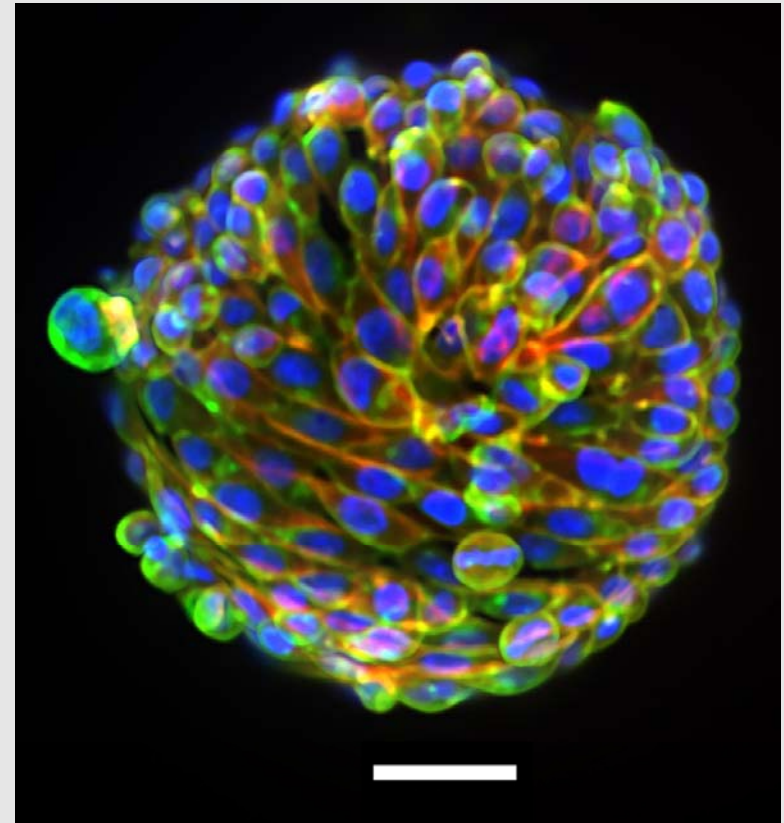

Cell culture. *Simplified.*

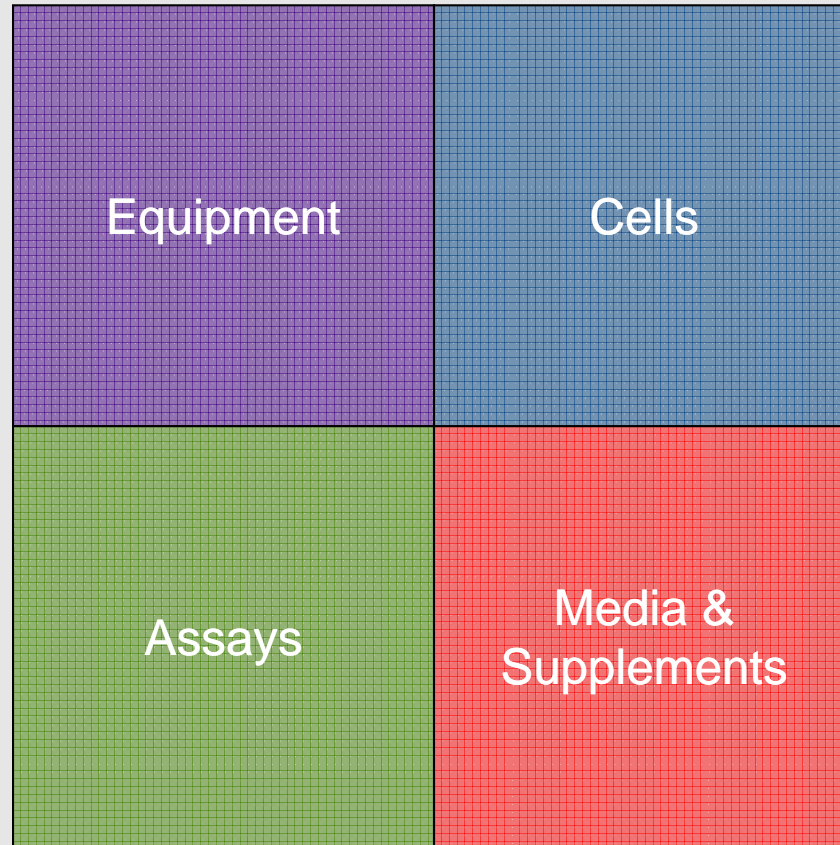
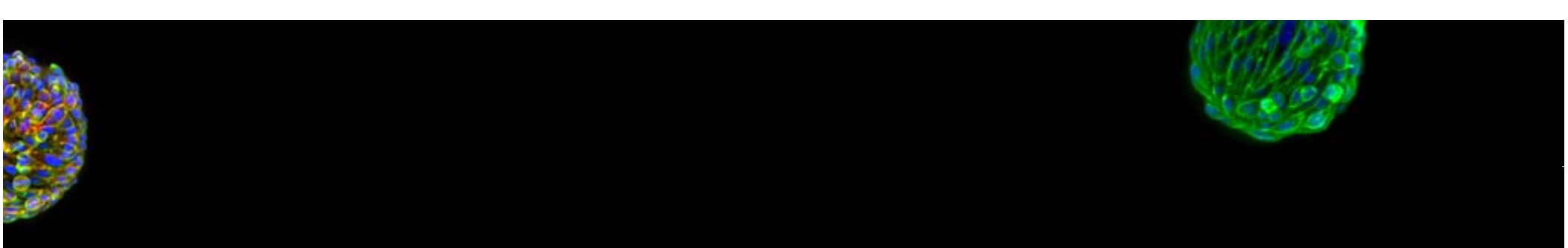

Cell culture. *Simplified.*